

▲ WARNING: Cycling can be dangerous. Bicycle products should be installed and serviced by a professional mechanic. Never modify your bicycle or accessories. Read and follow all product instructions and warnings including information on the manufacturer's website. Inspect your bicycle before every use. Always wear a helmet.

Compatibility & Intended Use: ASTM 3

CONDITION	DESCRIPTION
	<p>This is a set of conditions for operation of a bicycle that includes Condition 1 and Condition 2 as well as rough trails, rough unpaved roads, and rough terrain and unimproved trails that require technical skills. Jumps and drops are intended to be less than 61 cm (24").</p>

▲ WARNING: Not intended for use with carbon handlebars or carbon steerer tubes.

Additional Product and Safety Information can be found at the website: www.mswbike.com/safety.

Tools Required

- 4mm and 5mm metric hex-bit sockets
- Ratchet (optional)
- Torque wrench with Newton meter (Nm) scale
- Metal file or fine-grit sandpaper
- Grease

NOTE: Make sure the headset is in good condition and properly installed before installing a new stem. The steerer and handlebar mating surfaces must be clean and free of dirt, lubricant, and any retaining compounds.

NOTE: Note the angle of the bars and the position of the brake levers and shifters before removing your old stem. This will allow you to replicate these positions after installing the new stem.

▲ WARNING: Damage in the handlebar clamping area can compromise the handlebar's structural integrity and may result in product failure. Inspect your handlebar carefully for cracks, scratches, gouging or other damage before reinstallation. Replace handlebar if necessary.

Threadless Stem Installation

If your old stem has a removable face plate, you do not have to remove the brake levers, shifters or any other handlebar mounted accessories to install the new stem. Simply unbolt the stem face plate and remove the handlebar. Then hold the fork securely while you remove the old stem to prevent the fork from falling out of the headset.

1. Install the fork and headset according to the instructions given by the manufacturers of those products.
2. Install cable hangers and all spacers first. Remove the stem binder bolts and lubricate them with grease. Reinstall them loosely but do not tighten. Then slide the stem onto the steerer.
3. Push the stem down on the steerer as far as it will go, making sure everything is seated properly. Then tighten one binder bolt just enough to temporarily secure the stem to the steerer.

4. Always use a 10mm spacer above the stem. The top of the steerer should be 2–3mm below the top of the 10mm spacer (Fig. 1). If the steerer is too long with the desired amount of spacers installed, it must be cut and the headset star-nut or compression plug repositioned. If the steerer is too short, there won't be enough clamping surface for the stem to be installed securely. Remove spacers to adhere to dimensions listed above. Do not use if the above dimensions cannot be met.

▲ WARNING: Installing a stem onto a steerer that is too short may cause failure of the steerer or stem and result in a crash and serious injury.

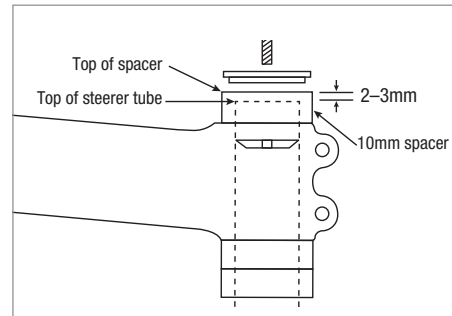

Figure 1

5. Lubricate the top cap anchor bolt with grease. Place the top cap into the 10mm spacer on top of the stem. Then thread the anchor bolt into the star-nut or compression plug as far as it will go.
6. Loosen the binder bolt tightened in step 3. Using a torque wrench and hex-bit socket, tighten the top cap anchor bolt to the torque specified by the headset manufacturer. Make sure there is no binding or play (looseness) in the headset.
7. Remove the face clamp bolts and lubricate the threads with grease. Inspect the stem's handlebar clamping area for any burrs and remove with a metal file or sandpaper. Locate the handlebar in the stem, place the faceplate onto the stem and insert the bolts. Tighten the bolts just enough to hold the bar in place.
8. Align the stem with the frame/front wheel (Fig. 2). Once aligned, use a torque wrench and hex-bit socket to alternately tighten the two stem steerer binder bolts to the torque listed on the stem.

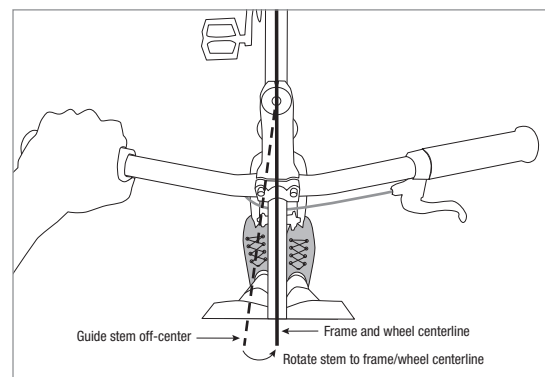

Figure 2

9. Check for headset play. If you discover any play, loosen the steerer clamp bolts and tighten the top cap anchor bolt an additional 1/16th turn. Then align the stem, and retighten the binder bolts to the recommended torque listed on the stem. Repeat until proper adjustment is made.
10. Adjust handlebar position in stem, center handlebar in stem clamp, and rotate bar to desired angle.

- Alternately tighten the faceplate bolts following the tightening sequence in Fig 3. Turn each bolt in half-turn increments until they reach a torque of 5–8Nm. Do not exceed the lowest maximum torque rating marked on any of the components. Then check the upper and lower gaps between the front cap and the rear portion of the handlebar clamp to make sure they are equal (Fig. 4).

▲ WARNING: Improper installation of bolts may lead to product failure, causing serious injury. Do not exceed specified torque values. Periodically inspect bolts and retighten if required.

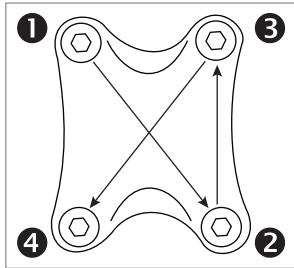

Figure 3

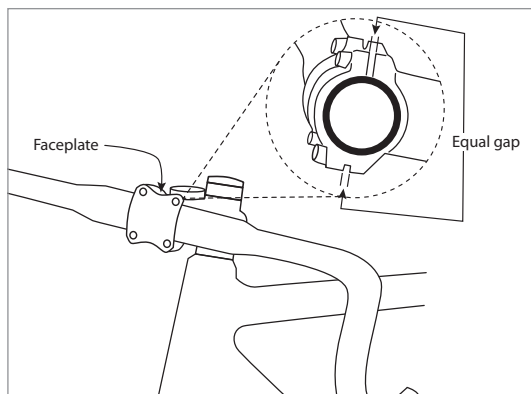

Figure 4

- Install the control components onto the handlebar, if necessary. Do not exceed the maximum torque specifications for any component.
- Perform a final check. Straddle the toptube, squeezing the front wheel between your legs. Grab the control levers or grips and make a strong attempt to rotate the handlebar up or down and back and forth.

Ongoing Maintenance

Periodically check to make sure the stem bolts for the steerer tube clamp and stem faceplate are properly torqued to the indicated specification.

Periodically inspect your stem, handlebar, fork, and frame for any signs of cracking or damage, especially after a crash or other impact. If in doubt, have your bicycle inspected by a professional bicycle mechanic.

Limited Warranty

This product is warranted against defects in materials and workmanship for 2 years from the date of retail purchase of the product, subject to the limitations detailed below. Save your dated receipt for proof of purchase.

This warranty does NOT cover the following:

- Damage due to improper assembly or follow-up maintenance or lack of skill, competence or experience of the user or assembler
- Products that have been modified, neglected, used in competition or for commercial purposes, misused or abused, involved in accidents or anything other than normal use

- Installation of components, parts or accessories not originally intended for or compatible with product as sold
- Damage or deterioration to the paint, surface finish, aesthetics or appearance of the product
- Normal wear and tear
- Labor required to remove and/or refit and re-adjust the product within the bicycle assembly

This limited warranty is expressly limited to the repair or replacement of the original product, at the option of MSW, and is the sole remedy of the warranty. This limited warranty applies only to the original purchaser of the MSW product and is not transferable. This warranty applies only to products purchased through an authorized dealer or distributor. In no event shall MSW be liable for any loss, inconvenience or damage, whether direct, incidental, consequential, or otherwise resulting from breach of any express or implied warranty or condition, of merchantability, fitness for a particular purpose, or otherwise with respect to MSW products except as set forth herein.

This warranty gives the consumer specific legal rights, and those rights and other rights may vary from place to place. This warranty does not affect your statutory rights.

TO THE EXTENT NOT PROHIBITED BY LAW, THESE WARRANTIES ARE EXCLUSIVE AND THERE ARE NO OTHER EXPRESS OR IMPLIED WARRANTIES OR CONDITIONS INCLUDING WARRANTIES OR CONDITIONS OF MERCHANTABILITY AND FITNESS FOR A PARTICULAR PURPOSE.

Warranty Registration: Proof of purchase is required before a warranty claim is processed. MSW therefore strongly encourages warranty registration at www.mswbike.com. Failure to register will not affect consumer rights under the limited warranty stated above, so long as the consumer can show in a reasonable manner proof of original ownership and the date the MSW product was purchased. If you have any questions contact warranty@www.mswbike.com.

Submitting a Claim can be made anywhere MSW products are sold. When in doubt, contact your local shop. Please provide details about what happened including but not limited to other components used in conjunction with the alleged defective MSW part.

NOTE: The term of the Warranty is not a guarantee of the product's useful life. Product life is influenced by how the product is used, stored, and maintained over time. The Warranty is not meant to suggest the product cannot be broken or that the product will last forever. The Warranty only means the product is covered subject to the terms of the Warranty.

Produkthinweise finden Sie auf der Website: mswbike.com/safety.

Las instrucciones del producto pueden encontrarse en el sitio web: mswbike.com/safety.

Le mode d'emploi est disponible sur le site Web : mswbike.com/safety.

Le istruzioni sul prodotto si trovano sul sito: mswbike.com/safety.

製品取扱説明書はウェブサイトにあります: mswbike.com/safety.